



# 承 认 书

## SPECIFICATION FOR APPROVAL

客 户 CUSTOMER :  
 品 名 PART NAME: 6006 鼓风机 3 线 3pin 液压轴承  
 型 号 TYPE NO : BF06006H05FP  
 送 样 数 量 QUANTITY:  
 送 样 日 期 DATE :  
 样 品 单 号 SAMPLE NO:  
 客 户 料 号 CUSTOMER PART NUMBER :

**感谢您给予本公司送样承认的机会, 烦请将此表回签本公司便于归档。谢谢!**

客 户 确 认 CUSTOMER APPROVE	
承 认 APPEOVED	日 期 DATE
盖 章 SIGNATURES	

供 应 商 SUPPLIER		
审 核 APPROVE	制 作 DATE	日 期 DATE
盖 章 SIGNATURES		

正凌精密工业(广东)有限公司

电话: 020-84551166 传真: 020-84551168

地址: 广州市番禺区石基镇官涌村段24号

<http://www.NexttronGroup.com>

1. 这份文件定义直流无刷风机电器机械特性

This documentation defines the Electrical and Mechanical characteristics of DC Brushless Fans.

2. 环境条件标准 (Standard Environmental Condition)

在标准温度 25℃，相对湿度 65%下，且允许在环境温度 10-35℃，相对湿度 25-80%中测试。

Temperature 25℃, relative humidity 65% shall be standard if no doubt arises in the judgment. However it is permitted that test are conducted in the environment of temperature 10~35℃, relative humidity 25~80%.

3. 产品特性 (Products Characters)

3-1	规格类型 (Item)	规格参数值 ( Specification Conditions)
3-2	外形尺寸 (Size of outline )	60.5*56.5*6.0MM
3-3	额定电压 (RATED VOLTAGE)	DC 5.0V
3-4	电压范围 (Operating Voltage)	4.5-5.5V
3-5	启动电压 (Starting Voltage)	≥ 3.5V ON/OFF
3-6	额定电流 (Max. Rated Current)	≅ 0.35A
3-7	额定功率 (Max. Input Power)	1.75W
3-8	额定转速 (Max Rated Speed)	4500RPM±10%
3-9	风量 (Air Flow)	3.97CFM
3-10	风压 (Static pressure)	12.46mmH2O
3-11	噪音值 (Noise Value)	34.3dBA
3-12	输出信号 (Output signal)	FG
3-13	极性保护功能 (Polarity protection )	YES
3-14	自动启动保护功能 (Auto Restart Protection)	YES
3-15	锁定保护功能 (lock protection )	YES
3-16	极数 (No. of Polar)	4
3-17	轴承类型 (Bearing Type)	液压轴承 Hydraulic Bearing
3-18	预计寿命 (Life Expectancy)	30000 小时
3-19	连接器 (Connector)	1.25/3P/3 线
3-20	绝缘等级 (Insulation Class)	Class-a
3-21	运转相对温度 (Operating temperature)	-10℃ to +50℃
3-22	储存相对温度 (Storage temperature)	-15℃ to +70℃

4. 特别检验 (Special inspection)

4-1	锁定保护 (Locked rotor protection)	在额定电压工作锁定 72 小时不能产生燃烧现象 Locked rotor protection:The burning cannot be produced when restricted for 72 hours at The rated voltage.
4-2	落地测试 (Drop test)	马达能在最少包装情况下, 分别 3 面于 60MM 高度自由跌落在 10MM 木板上, 无断裂。 Motor withstands one free body drop from 60cm in height onto 10mm thickness of wooden board for each of them three faces in minimum packaging condition. NO fracture.
4-3	绝缘强度 (INSULATION STRENGTH)	在通入 500V 直流电压条件下, 外框与端子线间阻抗不低于 10 兆欧姆。 Under the condition of ventilation with 500 v DC voltage, Between frame and terminal impedance is Not less than 10 meg ohm.
4-4	绝缘耐压强度 (Dielectric strength)	在通入 500V/60Hz 交流电压一分钟条件下, 外框与端子线之间电流不超过 5mA。 In going into 500 v / 60 Hz ac voltage under the condition of one minute, between frame and terminal current is not more than 5 mA.
4-5	预计寿命(Life expectancy)	在环境稳定为 25℃, 相对湿度为 15-65%RH 的条件下, 预期工作时间为 30000 小时。 In a stable environment for 25 °C, relative humidity conditions for 15-65% RH, expected work time is 30000 hours.
4-6	电源线 (Lead wires)	UL1571 #32 Black cathode (-) Red positive pole(+) YELLOW FG
4-7	材质 (Material)	外框: PBT 防火料 UL94V-0 outline border: PBT fireproofing UL94V-0 扇叶: PBT 防火料 UL94V-0 blower flabellum PBT fireproofing UL94V-0
4-8	尺寸规格 (Dimensions)	参照尺寸图纸 (See Dimensions Drawing)

## 5. 特性定义 (Characteristics definition):

5.1 额定电流: 在温度为 25°C. 相对湿度 65%的条件下, 连续以额定电压运转 3 分钟后测量出来的电流值.

Rated current:Rated current shall measured after 3 minutes of continuous rotation at rated voltage in clean air at 25°C,under 65%RH.

5.2 额定转速: 在温度 25°C.相对湿度 65%的条件下, 连续以额定电压运转 3 分钟后测量出来的转速值。

Rated speed:Rated speed shall be measured after3 minutes of rotation at rated voltage in clean air at 25°C,under 65%RH.

5.3 启动电压: 当风扇通电启动时的电压值。

Start Voltage:The voltage that is able to start the fan to operate by suddenly witching on.

5.4 噪音值: 在噪音测试房中, 放置麦克风于进风口一米处, 并参考 ISO-7779 规格测量出来。背景噪音: 15dBA 最大

Noise level:In the noise test room,put the microphone in the inlet one meters, and refer To the ISO -7779 specification is measured.background noise:15 dBA is the largest.

在无声室额定电压之噪音测试

Noise is Measured At Rated Voltage In Anechoic

在空气自由流动的测试室

Chamber in free air As Below

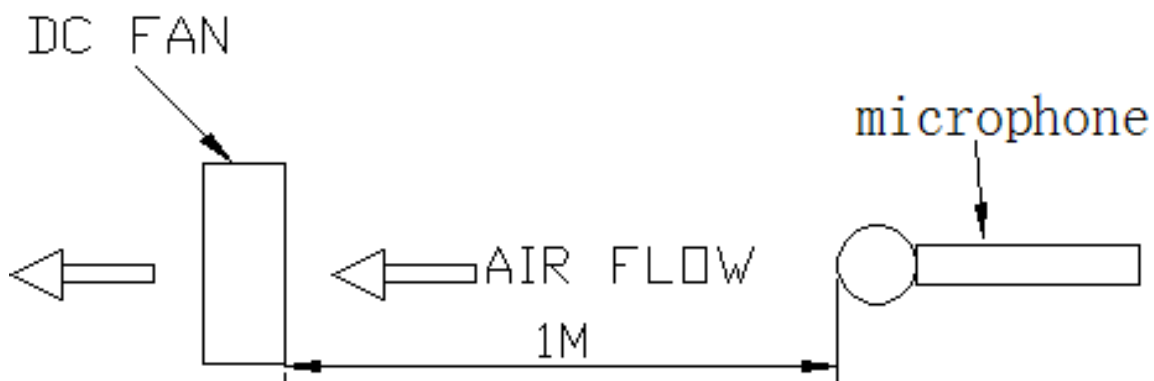

6 标签 Label:

样式Style



7. 风量/风压曲线 Air flow/Air pressure curve

测试条件 Test Condition:

温度 Temperature: 常规温度 Room temperature

湿度 Humidity: 65%

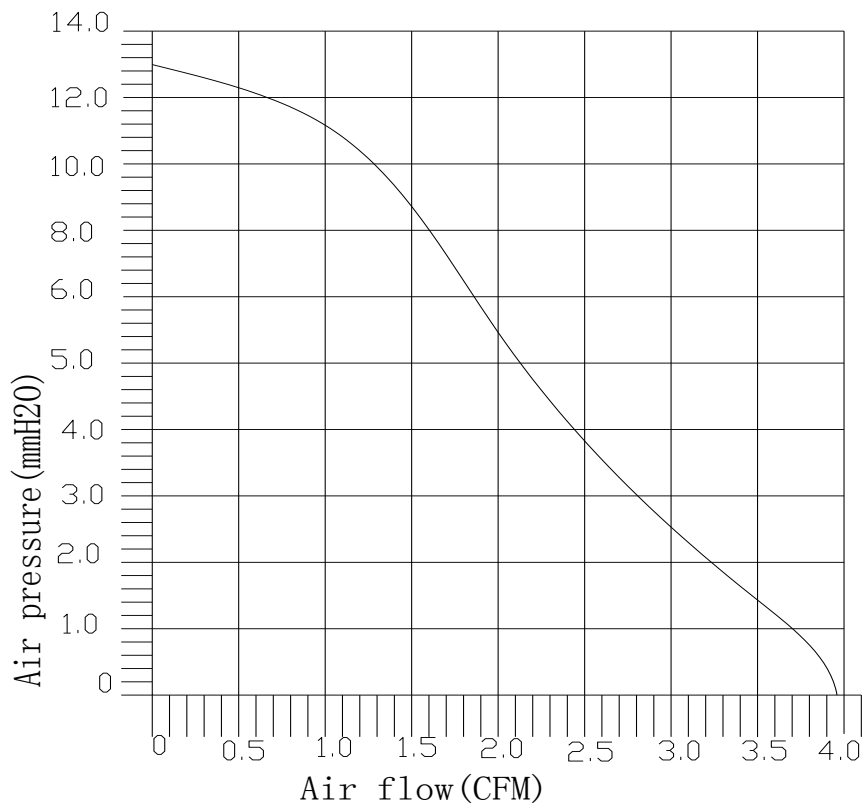

8. 波形特性图 Sensor feature scheme:

8.1 信号线将传送一系列方形波至主机板，以表示风扇工作良好。

Signal lines will sent a series of square wave to the motherboard, to indicate that the fan works well.

8.2 在异常情况下，风扇停止转动，则输出频率为零。

In exceptional cases, fan stop running, the output frequency is zero.

8.3 输出信号 output signal:

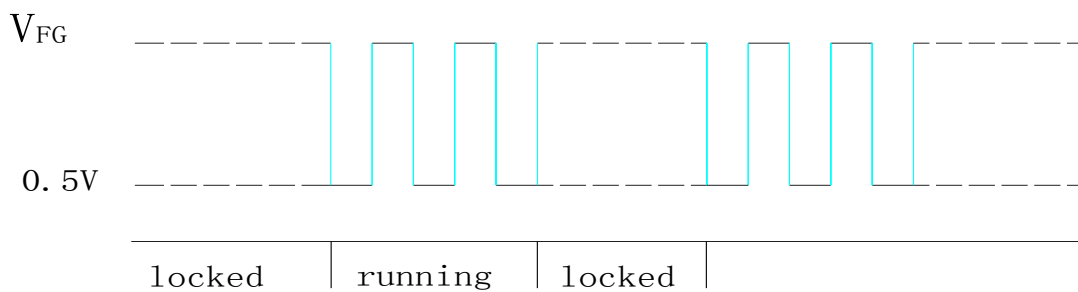

8.4 风扇运转为4极2周期 Fan running for 4poles 2pulses

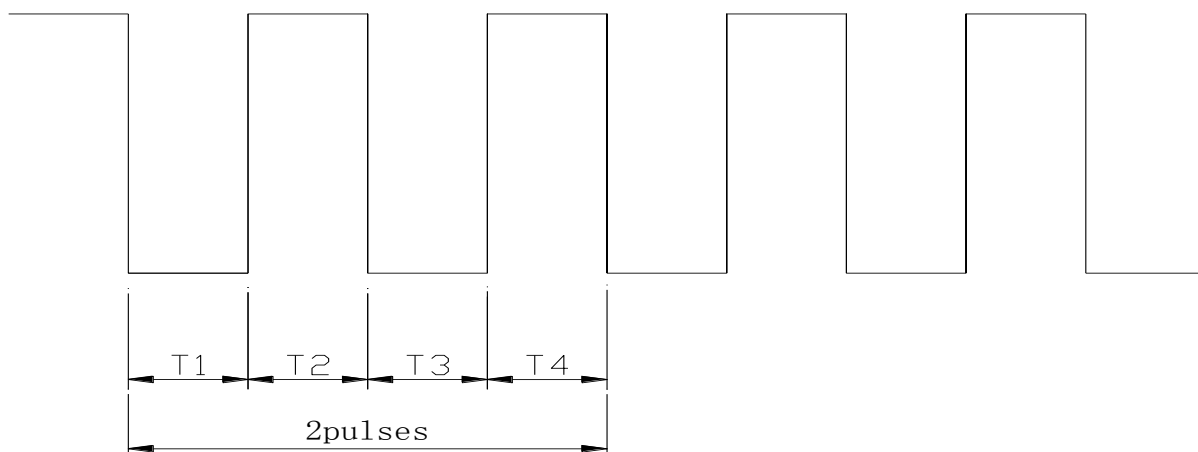

10. 外形尺寸图 (outline dimensional drawing)

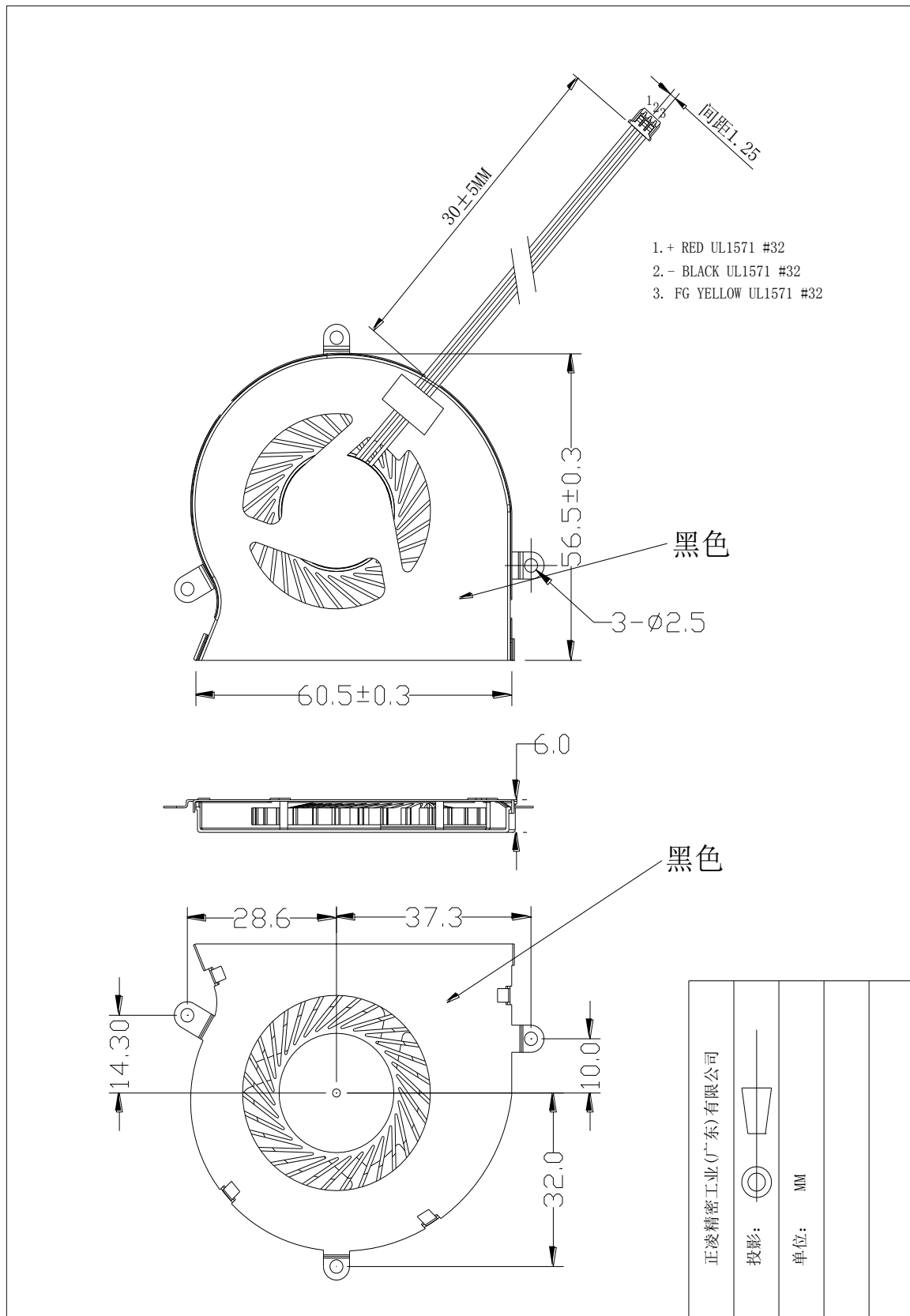

## 風扇使用注意事項



### HOW TO HANDLE FAN PROPERLY?

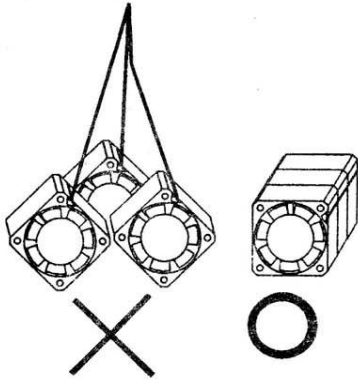

1. 取用風扇，輕取外框兩側，不可拉扯導線。

1. Hold the fan by frame side. Do not hold lead wires to support the fan.

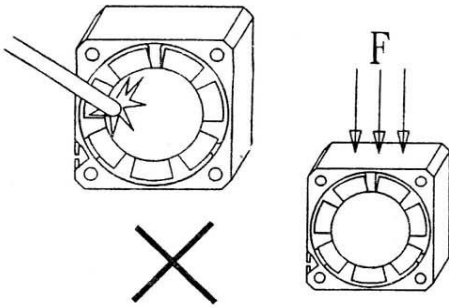

2. 取用風扇，不可碰觸或擠壓扇葉與外框。

2. No touching or pressing on the impeller hub.

Avoid crushing the frame side.

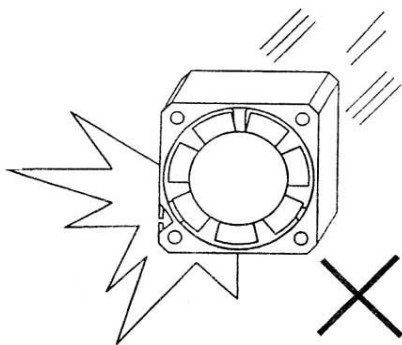

3. 風扇嚴禁掉落地面，或敲擊外框任何面。

3. Do not drop on the ground.

Do not pound on the frame side.

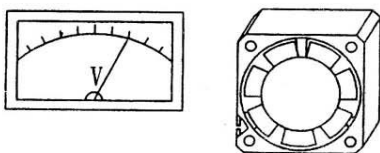

4. 風扇電源需依照規格電壓安裝使用。

4. Connect leads properly and apply voltage according to specification.